

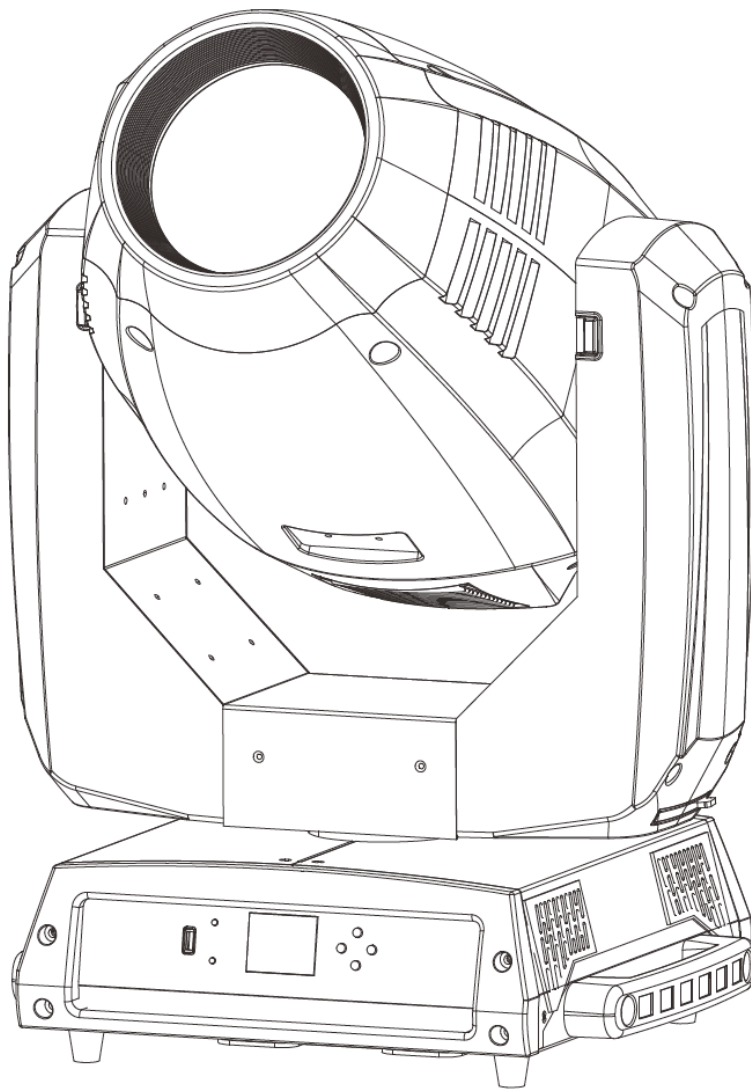

# VIZI CMY 16RX



## User Instructions



Introduction ..... 3

Safety Precautions ..... 5

Features, General Instructions, & Product Registration ..... 6

Handling Precautions & Important Discharge Lamp Warnings..... 7

Mounting ..... 9

Base Layout ..... 11

DMX Setup ..... 12

Control by Universal DMX Controller.....15

Gobo and Color Wheels ..... 16

DMX Mode Values and Traits ..... 17

System Menu ..... 26

Error Information ..... 35

Lamp and Fuse Replacement ..... 36

Cleaning ..... 37

Changing the Gobo ..... 38

Trouble Shooting.....39

Specifications ..... 40

Warranty ..... 41

Optional Accessories ..... 42

©2021 ADJ Products, LLC all rights reserved. Information, specifications, diagrams, images, and instructions herein are subject to change without notice. ADJ Products, LLC logo and identifying product names and numbers herein are trademarks of ADJ Products, LLC. Copyright protection claimed includes all forms and matters of copyrightable materials and information now allowed by statutory or judicial law or hereinafter granted. Product names used in this document may be trademarks or registered trademarks of their respective companies and are hereby acknowledged. All non-ADJ Products, LLC brands and product names are trademarks or registered trademarks of their respective companies.

**ADJ Products, LLC** and all affiliated companies hereby disclaim any and all liabilities for property, equipment, building, and electrical damages, injuries to any persons, and direct or indirect economic loss associated with the use or reliance of any information contained within this document, and/or as a result of thezaimproper, unsafe, insufficient and negligent assembly, installation, rigging, and operation of this product.

#### **FCC STATEMENT**

This device complies with Part 15 of the FCC Rules. Operation is subject to the following two conditions: (1) this device may not cause harmful interference, and (2) this device must accept any interference received, including interference that may cause undesired operation.

#### **FCC RADIO FREQUENCY INTERFERENCE WARNINGS & INSTRUCTIONS**

This product has been tested and found to comply with the limits as per Part 15 of the FCC Rules. These limits are designed to provide reasonable protection against harmful interference in a residential installation. This device uses and can radiate radio frequency energy and, if not installed and used in accordance with the included instructions, may cause harmful interference to radio communications. However, there is no guarantee that interference will not occur in a particular installation. If this device does cause harmful interference to radio or television reception, which can be determined by turning the device off and on, the user is encouraged to try to correct the interference by one or more of the following methods:

- Reorient or relocate the device.
- Increase the separation between the device and the receiver.
- Connect the device to an electrical outlet on a circuit different from which the radio receiver is connected.
- Consult the dealer or an experienced radio/TV technician for help.

#### **Energy Saving Matters (EuP 2009/125/EC)**

Saving electric energy is a key to help protecting the environment. Please turn off all electrical products when they are not in use. To avoid power consumption in idle mode, disconnect all electrical equipment from power when not in use. Thank you!

**Overview:** The Vizi CMY 16RX is a DMX intelligent, moving head fixture. The Vizi CMY 16RX is a 22/24-channel DMX unit. This fixture is a DMX controlled unit. For best results use fog or special effects smoke to enhance the beams projections. During the initial start-up or use of this product a light smoke or smell may arise from the unit. This is a normal process and is caused by the heat associated with the lamp.

***This product is intended to be used by professionally trained personnel only and is not suitable for private use***

**Unpacking:** Thank you for purchasing the Vizi CMY 16RX by ADJ Products, LLC. Every Vizi CMY 16RX has been thoroughly tested and has been shipped in perfect operating condition. Carefully check the shipping carton for damage that may have occurred during shipping. If the carton appears to be damaged, carefully inspect your fixture for any damage and be sure all equipment necessary to operate the unit has arrived intact. In the event damage has been found or parts are missing, please contact our toll free customer support number for further instructions. Please do not return this unit to your dealer without contacting customer support first.

**CUSTOMER SUPPORT:** Contact ADJ Service for any product related service and support needs. Please visit [forums.adj.com](http://forums.adj.com) with questions, comments or suggestions.

**REPLACEMENT PARTS** please visit [parts.adj.com](http://parts.adj.com)

**ADJ SERVICE USA - Monday - Friday 8:00am to 4:30pm PST**  
 800-322-6337 | Fax 323-582-2941 | [support@adj.com](mailto:support@adj.com)

**ADJ SERVICE EUROPE - Monday - Friday 08:30 to 17:00 CET**  
 +31 45 546 85 60 | Fax +31 45 546 85 96 | [support@adj.eu](mailto:support@adj.eu)

**ADJ PRODUCTS LLC USA**  
 6122 S. Eastern Ave. Los Angeles, CA. 90040  
 323-582-2650 | Fax 323-532-2941 | [www.adj.com](http://www.adj.com) | [info@adj.com](mailto:info@adj.com)

**ADJ SUPPLY Europe B.V**  
 Junostraat 2 6468 EW Kerkrade, The Netherlands  
 +31 (0)45 546 85 00 | Fax +31 45 546 85 99 | [www.adj.eu](http://www.adj.eu) | [info@americandj.eu](mailto:info@americandj.eu)

**ADJ PRODUCTS GROUP Mexico**  
 AV Santa Ana 30 Parque Industrial Lerma, Lerma, Mexico 52000  
 +52 (728) 282-7070 | [ventas@adj.com](mailto:ventas@adj.com)

**DOCUMENT VERSION**

Date	Document Version	Software Version	DMX Channel Mode	Notes
08/2018	1	1.0	22/24	Initial release
10/2018	1.1	1.1	22/24	Menu update
11/2018	1.2	1.1	22/24	Add static gobo images
11/19/19	1.3	NC	N/C	Updated DMX channel values.
02/23/21	1.4	NC	N/C	Updated Important Lamp Discharge Warnings

***Please Read and Understand This Manual Completely Before You Attempt To Install Or Operate This Unit!***

- To reduce the risk of electrical shock or fire, do not expose this unit rain or moisture.
- Do not spill water or other liquids into or on to your unit.
- Be sure that the local power outlet matches that of the required voltage for your unit.
- Do not attempt to operate this unit if the power cord has been frayed or broken.
- Do not attempt to remove or break off the ground prong from the electrical cord. This prong is used to reduce the risk of electrical shock and fire in case of an internal short.
- Disconnect from main power before making any type of connection.
- Do not remove the cover under any conditions. There are no user serviceable parts inside.
- Never operate this unit when its cover is removed.
- Always be sure to mount this unit in an area that will allow proper ventilation. Allow about 6" (15cm) between this device and a wall.
- Do not attempt to operate this unit if it becomes damaged.
- This unit is intended for indoor use only; use of this product outdoors voids all warranties.
- Always mount this unit in safe and stable matter.
- Power-supply cords should be routed so that they are not likely to be walked on or pinched by items placed upon or against them, paying particular attention to cords at plugs, convenience receptacles and the point where they exit from the appliance.
- The fixture should be cleaned only as recommended by the manufacturer. See page 36 for cleaning details.
- This fixture should be situated away from heat sources such as radiators, heat registers, stoves, or other appliances (including amplifiers) that produce heat.
- The fixture should be serviced by qualified service personnel when:
  - A. Objects have fallen, or liquid has been spilled into the appliance.
  - B. The appliance has been exposed to rain or water.
  - C. The appliance does not appear to operate normally or exhibits a marked change in performance.

***WARNING! CAUTION! FIRE HAZARD! DUE TO THE EXTREME HEAT CAUSED BY THIS LAMP, THE MINIMUM DISTANCE TO LIGHTED OBJECTS IS 12 METERS (40FT).***

- Philips® Platinum 16R Discharge Lamp
- Micro-Stepping Motors for Smooth Color and Gobo Transitions
- DMX-512 Protocol Compatible (2 DMX Channel Modes: 22 or 24 channels)
- 3/5-Pin XLR In/Out
- Full CMY Color Mixing
- Independent Gobo and Color Wheels
- 2 Separate Gobo Wheels
- 9 static gobos and 6 static apertures
- 9 rotating, replaceable gobos
- Frost Filter
- Strobe Effect
- Motorized Focus
- Motorized Zoom
- 540° Pan Movement
- 270° Tilt Movement
- Pan/Tilt Invert
- Pan/Tilt Speed Adjustment
- Digital Display for Address and Function Setting

To optimize the performance of this product, please read these operating instructions carefully to become familiarized with the basic operations of this unit. These instructions contain important safety information regarding the use and maintenance of this unit. Please keep this manual with the unit, for future reference.

The Vizi CMY 16RX carries a one-year limited warranty. Please fill out the enclosed warranty card to validate your purchase. All returned service items whether under warranty or not, must be freight prepaid and accompany a return authorization (R.A.) number. The R.A. number must be clearly written on the outside of the return package. A brief description of the problem as well as the R.A. number must also be written down on a piece of paper and included in the shipping carton. If the unit is under warranty, you must provide a copy of your proof of purchase invoice. You may obtain a R.A. number by contacting our customer support team on our toll free customer support number. All packages returned to the service department not displaying a R.A. number on the outside of the package will be returned to the shipper at the shippers cost.

Caution! There are no user serviceable parts inside this unit. Do not attempt any repairs yourself, doing so will void your manufactures warranty. In the unlikely event your unit may require service please contact ADJ Products, LLC. During operation the housing may become extremely hot. Avoid touching the unit with bare hands while in use. ADJ will not accept any liability for any resulting damages caused by the non-observance.

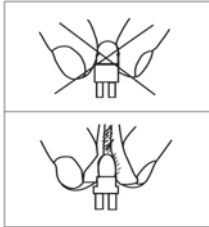

This fixture is fitted with a discharge lamp, which is highly susceptible to damage if improperly handled. Never touch the lamp with your bare fingers, as the oil from your hands will shorten lamp life. Also, never move the fixture until the lamps have had ample time to cool. Remember, lamps are not covered under warranty conditions.

This unit emits intense UV radiation, which is harmful to the eyes and skin. The intense luminance of the lamp can cause severe damage to the retina. Never operate this unit without its covers, these covers have been specially designed to shield against UV radiation.

**Epileptic Warning:** Those suffering from epilepsy should avoid looking directly into the lamp at all times.

Avoid switching the fixture on and off repeatedly in short intervals, as this will reduce lamp life and intensity.

To achieve the intensity associated with discharge lamps, these lamps use gas sealed in a high-pressure environment to emit a brilliant output. Due to the high pressure involved with the construction of the lamp, the lamp may explode during prolonged extensive use. This risk is increased with age; added care is encouraged when dealing with older lamps. Extreme caution should be used when operating this or any fixture fitted with a gas discharge lamp. Never open this unit while in use.

**VERY IMPORTANT:** This is for your safety and the life length of the unit. The Philips® Platinum 16R Discharge lamp has lifetime of 1500 hours. ADJ recommends periodically checking the lamp running time (see page 27 “Light Hour Use”). When the lamp reaches the 1500-hour mark, or close to it, we strongly suggest you switch the lamp out.

Replace the lamp following the instructions on pages 35-36. After replacing the lamp you must clear the LAMP RUNNING TIME (see page 27 “Light Hour Use”).

**Warning: DO NOT use this lamp more than 1500 hours. Using the lamp any longer than the set life could seriously damage your unit.**

**WARNING! CAUTION! FIRE HAZARD! DUE TO THE EXTREME HEAT CAUSED BY THIS LAMP, THE MINIMUM DISTANCE TO LIGHTED OBJECTS IS 12 METERS (40FT).**

**LAMP REPLACEMENT WARNING (Software Version > V1.4)**

**At 1200 hours**, the display shall flash **“Replace Lamp Soon”** for up to 10 minutes. The user may press Enter to acknowledge the warning and exit into the main menu for normal operation.

**At 1500 hours**, the display shall flash **“Replace Lamp Now”** for up to 10 minutes. The user may press Enter to acknowledge the warning and exit into the main menu for normal operation. The fixture should continue to work normally when the lamp life reaches its maximum operation hour mark during live use. Once the fixture is powered OFF and back ON, the fixture display should flash **“Replace Lamp Now”**.

**At 1700 hours**, the display shall flash **“Replace Lamp Now”** and the fixture will no longer respond to DMX commands and immediately enter a hibernation mode that will electronically discontinue all fixture functionality with the exception of a few menu commands. The fixture shall remain in hibernation mode until the lamp is replaced and the lamp clock has been reset.

The only menu items that the user will have the ability to view or execute are “Fixture Information” → “Light Use Hour” (in order to view the number of hours on the current lamp) → “Reset Time” (which must be used after replacing the lamp to reset the lamp time and regain access to the standard menu options).



When installing the unit, the trussing or area of installation must be able to hold 10 times the weight without any deformation. When installing the unit must be secured with a secondary safety attachment, e.g. and appropriate safety cable. Never stand directly below the unit when mounting, removing, or servicing the unit. Overhead mounting requires extensive experience, including calculating working load limits, installation material being used, and periodic safety inspection of all installation material and unit. If you lack these qualifications, do not attempt the installation yourself. A skilled person should check the installation once a year.

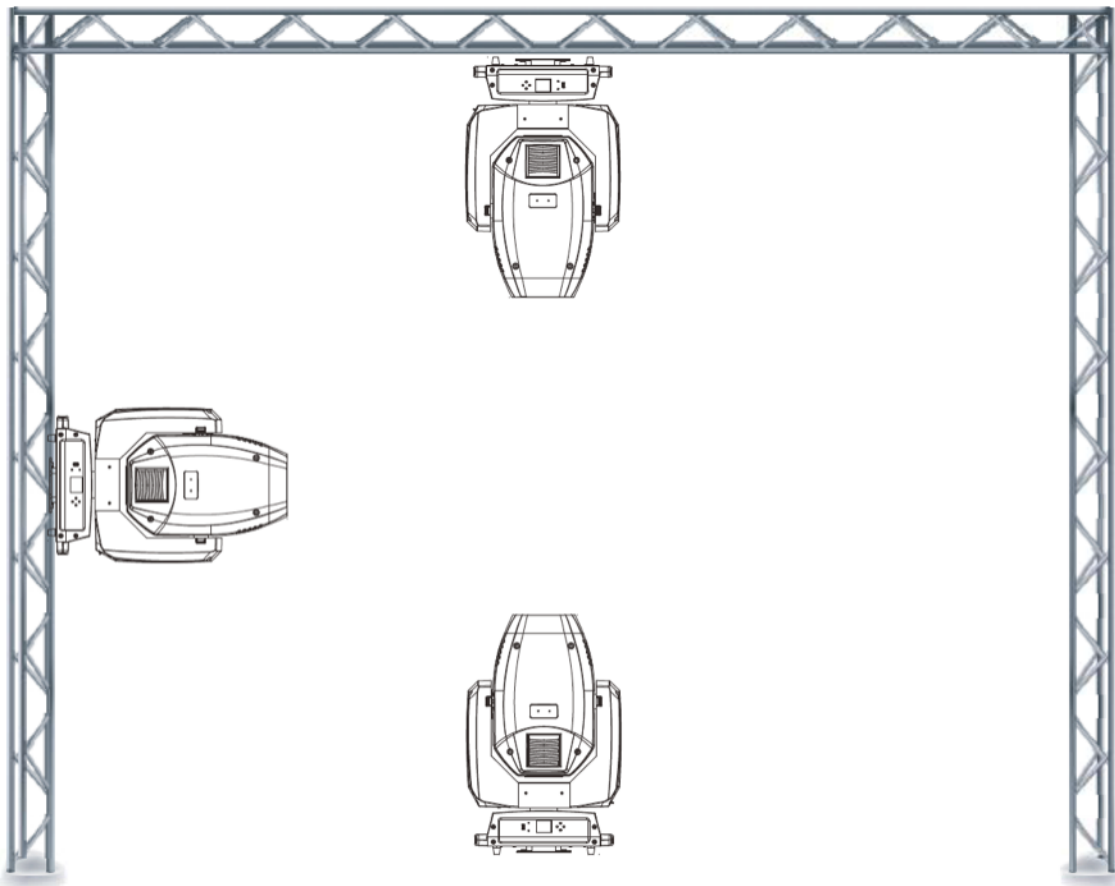

The Vizi CMY 16RX is fully operational in three different mounting positions, hanging upside-down from a ceiling, sideways on trussing, or set on a flat level surface. Be sure this fixture is kept at least 12m (40ft) away from any flammable materials (decoration etc.). Always use and install the supplied safety cable as a safety measure to prevent accidental damage and/or injury in the event the clamp fails (see next page). Never use the carrying handles for secondary attachment.

**NOTICE:** The suitable environmental temperature for this lighting fixture is between -25° C to 45° C. Do not place this lighting fixture in an environment where the temperatures are under or above the temperatures stated above. This will allow the fixture to run at its best and help prolong the fixture life.

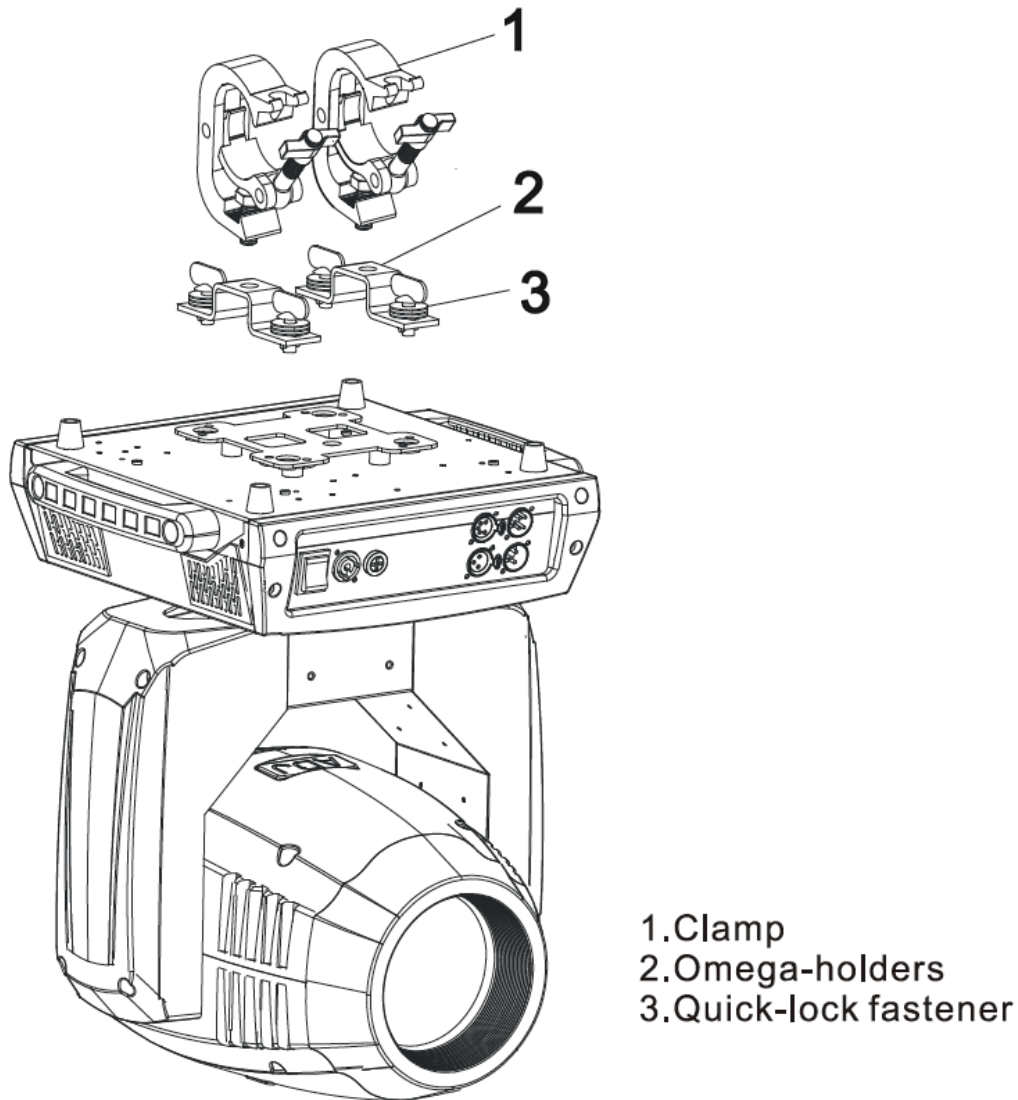

Screw one clamp each via a M12 screw and nut onto the Omega holders. Insert the quick-lock fasteners of the first Omega holder into the respective holes on the bottom of the Vizi CMY 16RX. Tighten the quick-lock fasteners fully clockwise. Install the second Omega holder. Pull the safety cable through the openings located on the base plate and over the trussing system or a safe fixation spot. Insert the end in the carabineer and tighten the safety screw.

**Front view**

**Rear view**

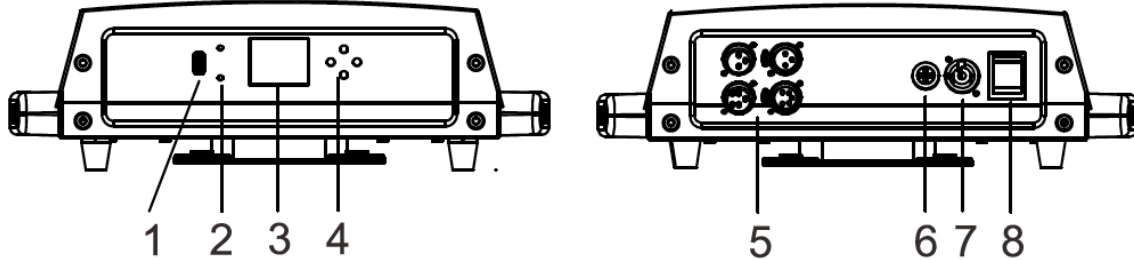

- 1. USB:
- 2. LED:

POWER	ON	Power On
DMX	ON	DMX input present

3. Display: Shows the selected function or various menus.

4. Button:

MENU	To enter into, move backward or leave the menu
UP	To go backward or to move up in the menu
DOWN	To go forward or to move down in the menu
ENTER	To perform the desired functions

5. DMX Input/Output: For DMX-512 Operation. Use 3 or 5-pin XLR cable to link multiple units together.

6. Fuse (T-10A): Protect the unit from damage of over current

7. Power: To connect to the mains supply.

8. Power Switch: Turns On/Off the power.

**Power Supply:** The Vizi CMY 16RX contains an electronic ballast, which will auto sense the voltage when it is plugged into the power source. With the electronic ballast you do not need to worry about wall voltage, this unit can be plugged in anywhere.

**DMX-512:** DMX is short for Digital Multiplex. This is a universal protocol used by most lighting and controller manufactures as a form of communication between intelligent fixtures and controllers. A DMX controller sends DMX data instructions from the controller to the fixture. DMX data is sent as serial data that travels from fixture to fixture via the DATA “IN” and DATA “OUT” XLR terminals located on all DMX fixtures (most controllers only have a DATA “OUT” terminal).

**DMX Linking:** DMX is a language allowing all makes and models of different manufactures to be linked together and operate from a single controller, as long as all fixtures and the controller are DMX compliant. To ensure proper DMX data transmission, when using several DMX fixtures try to use the shortest cable path possible. The order in which fixtures are connected in a DMX line does not influence the DMX addressing. For example, a fixture assigned a DMX address of 1 may be placed anywhere in a DMX line, at the beginning, at the end, or anywhere in the middle. Therefore, the first fixture controlled by the controller could be the last fixture in the chain. When a fixture is assigned a DMX address of 1, the DMX controller knows to send DATA assigned to address 1 to that unit, no matter where it is located in the DMX chain.

**Data Cable (DMX Cable) Requirements:** The Vizi CMY 16RX can be controlled via DMX-512 protocol. The Vizi CMY 16RX has two DMX channel modes (22 channel mode and 24 channel mode). The DMX address is set electronically using the controls on the rear panel of the unit. Your unit and your DMX controller require an approved DMX-512 110 Ohm Data cable for data input and data output (Figure 1). We recommend AccuCable DMX cables. If you are making your own cables, be sure to use standard 110-120 Ohm shielded cable (This cable be purchased at almost all professional sound and lighting stores). Your cables should be made with a male and female XLR connector on either end of the cable. Also remember that DMX cable must be daisy chained and cannot be split.



Figure 1

**Notice:** Be sure to follow figures two and three when making your own cables. Do not use the ground lug on the XLR connector. Do not connect the cable's shield conductor to the ground lug or allow the shield conductor to come in contact with the XLR's outer casing. Grounding the shield could cause a short circuit and erratic behavior.

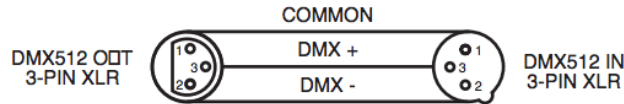

Figure 2

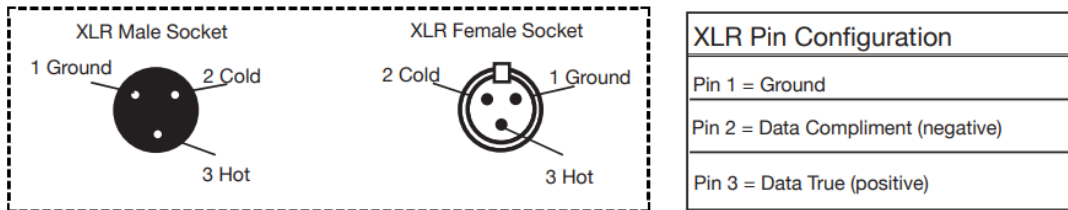
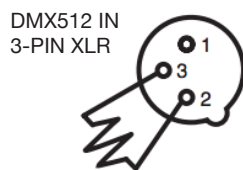

Figure 3

**Special Note: Line Termination:** When longer runs of cable are used, you may need to use a terminator on the last unit to avoid erratic behavior. A terminator is a 110-120 ohm 1/4 watt resistor, which is connected between pins 2 and 3 of a male XLR connector (DATA + and DATA -). This unit is inserted in the female XLR connector of the last unit in your daisy chain to terminate the line. Using a cable terminator (ADJ part number Z-DMX/T) will decrease the possibilities of erratic behavior.

Figure 4



Termination reduces signal errors and avoids signal transmission problems and interference. It is always advisable to connect a DMX terminal, (Resistance 120 Ohm 1/4 W) between PIN 2 (DMX-) and PIN 3 (DMX +) of the last fixture.

**5-Pin XLR DMX Connectors:** Some manufactures use 5-pin DMX-512 data cables for DATA transmission in place of 3-pin. 5-pin DMX fixtures may be implemented in a 3-pin DMX line. When inserting standard 5-pin data cables in to a 3-pin line a cable adaptor must be used, these adaptors are readily available at most electric stores. The chart below details a proper cable conversion.

<b>3-Pin XLR to 5-Pin XLR Conversion</b>		
Conductor	3-Pin XLR Female (Out)	5-Pin XLR Male (In)
Ground/Shield	Pin 1	Pin 1
Data Compliment (- signal)	Pin 2	Pin 2
Data True (+ signal)	Pin 3	Pin 3
Not Used		Pin 4 - Do Not Use
Not Used		Pin 5 - Do Not Use

**Universal DMX Control:** This function allows you to use a universal DMX-512 controller. A DMX controller allows you to create unique programs tailored to your individual needs.

1. The Vizi CMY 16RX has a 2 DMX channel modes (22 and 24 channels).  
See pages 16-24 for detailed description of the DMX traits.
2. To control your fixture in DMX mode, follow the set-up procedures on pages 14, 25-27 as well as the set-up specifications that are included with your DMX controller.
3. Follow the instructions on page 26 to select your desired DMX address.
4. Use the controller's faders to control the various DMX fixture traits.
5. For longer cable runs (more than a 100 feet) use a terminator on the last fixture.
6. For help operating in DMX mode consult the manual included with your DMX controller.

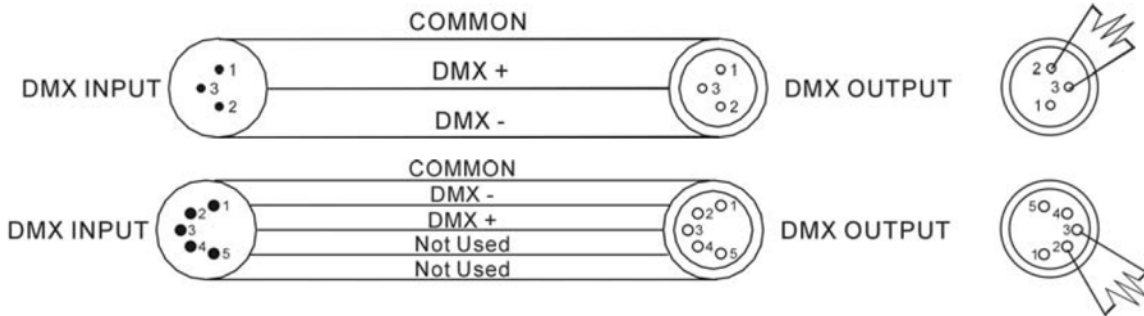
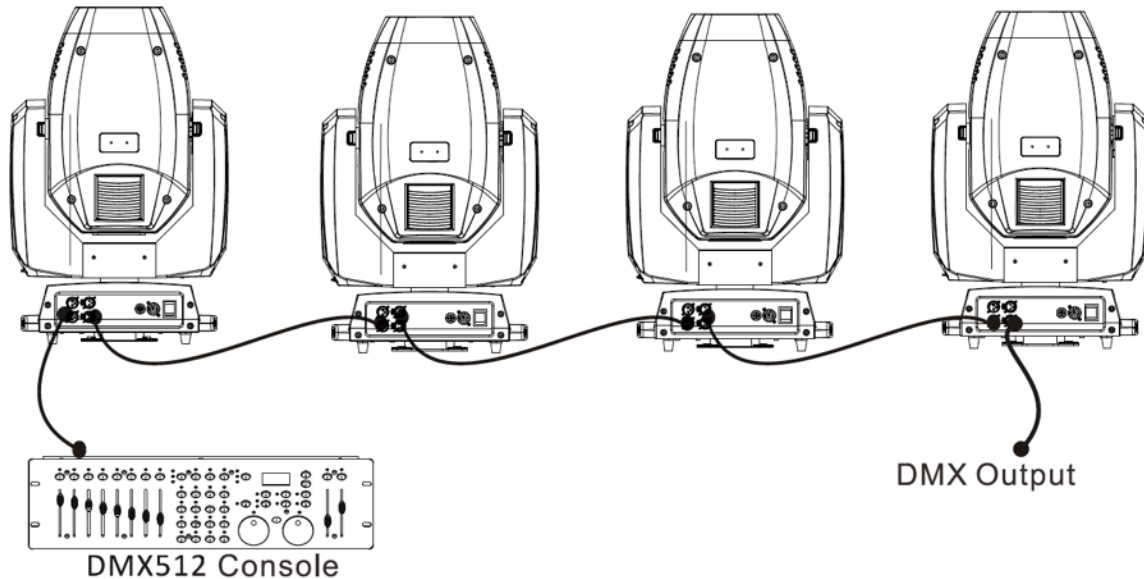

1. At last unit, the DMX cable has to be terminated with a terminator. Solder a 120-ohm 1/4W resistor between pin 2(DMX-) and pin 3(DMX+) into a 3-pin XLR-plug and plug it in the DMX-output of the last unit.
2. Connect the unit together in a “daisy chain” by XLR plug cable from the output of the unit to the input of the next unit. The cable cannot be branched or split to a “Y” cable. DMX 512 is a very high-speed signal. Inadequate or damaged cables, soldered joints or corroded connectors can easily
3. When power to one of the units is disconnected, the DMX output and input connectors are pass-through to maintain the DMX circuit,
4. Each lighting unit needs to have a DMX address to receive the data by the controller. The address number is between 0-511 (usually 0 & 1 are equal to 1).
5. The end of the DMX 512 system should be terminated to reduce signal errors.
6. 3 pin XLR connectors are more popular than 5 pin XLR connectors.
  - 3 pin XLR: Pin 1: GND, Pin 2: Negative signal (-), Pin 3: Positive signal (+)
  - 5 pin XLR: Pin 1: GND, Pin 2: Negative signal (-), Pin 3: Positive signal (+), Pin4, Pin5 not used.





**Static Gobo Wheel**

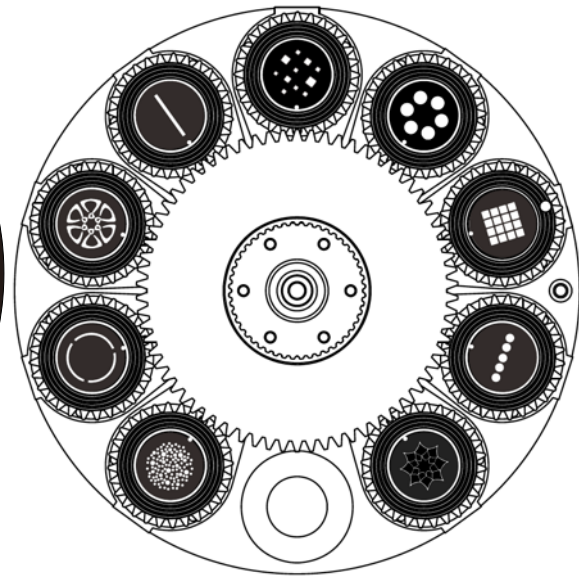

**Rotating Gobo Wheel**

**⚠ DANGER! ⚠**

*Before installing or changing the gobo wheel, make sure the device has been switched off.*



**Color Wheel**



**22 Channels:**

Channel	Value	Function
1	000 - 255	<b>Pan</b> 0° - 540°
2	000 - 255	<b>Pan Fine</b>
3	000 - 255	<b>Tilt</b> 0° - 270°
4	000 - 255	<b>Tilt Fine</b>
5	000 - 255	<b>Cyan</b> 0% - 100%
6	000 - 255	<b>Magenta</b> 0% - 100%
7	000 - 255	<b>Yellow</b> 0% - 100%
8		<b>Color</b>
	000-005	White
	006-011	Red
	012-017	Dark Orange
	018-023	Dark Green
	024-029	Dark Blue
	030-035	Pink
	036-041	Light Purple
	042-047	Light Green
	048-053	Light Orange
	054-059	Cyan
	060-127	White to Cyan
	128-189	Clockwise Rotation Fast to Slow
	190-193	Stop
	194-255	Counter-Clockwise Rotation Slow To Fast

Channel	Value	Function
9		<b>Static Gobo</b>
	000-002	White
	003-005	Gobo 1
	006-008	Gobo 2
	009-011	Gobo 3
	012-014	Gobo 4
	015-017	Gobo 5
	018-020	Gobo 6
	021-023	Gobo 7
	024-026	Gobo 8
	027-029	Gobo 9
	030-032	Gobo 10
	033-035	Gobo 11
	036-038	Gobo 12
	039-041	Gobo 13
	042-044	Gobo 14
	045-054	Gobo15
	055-058	Gobo1 Shaking Slow To Fast
	059-062	Gobo2 Shaking Slow To Fast
	063-066	Gobo3 Shaking Slow To Fast
	067-070	Gobo4 Shaking Slow To Fast
	071-074	Gobo5 Shaking Slow To Fast
	075-078	Gobo6 Shaking Slow To Fast
	079-082	Gobo7 Shaking Slow To Fast
	083-086	Gobo8 Shaking Slow To Fast
	087-090	Gobo9 Shaking Slow To Fast
	091-094	Gobo10 Shaking Slow To Fast
	095-098	Gobo11 Shaking Slow To Fast
	099-102	Gobo12 Shaking Slow To Fast
	103-106	Gobo13 Shaking Slow To Fast
	107-110	Gobo14 Shaking Slow To Fast
	111-127	Gobo15 Shaking Slow To Fast
128-189	Clockwise Rotation Fast to Slow	
190-193	Stop	
194-255	Counter-Clockwise Rotation Slow To Fast	

Channel	Value	Function
10		<b>Rotating Gobo</b>
	000-006	White
	007-013	Gobo1
	014-020	Gobo2
	021-027	Gobo3
	028-034	Gobo4
	035-041	Gobo5
	042-048	Gobo6
	049-055	Gobo7
	056-062	Gobo8
	063-083	Gobo9
	084-087	Gobo1 Shaking Slow To Fast
	088-092	Gobo2 Shaking Slow To Fast
	093-097	Gobo3 Shaking Slow To Fast
	098-102	Gobo4 Shaking Slow To Fast
	103-107	Gobo5 Shaking Slow To Fast
	108-112	Gobo6 Shaking Slow To Fast
	113-117	Gobo7 Shaking Slow To Fast
	118-122	Gobo8 Shaking Slow To Fast
	123-127	Gobo9 Shaking Slow To Fast
128-189	Clockwise Rotation Fast to Slow	
190-193	Stop	
194-255	Counter-Clockwise Rotation Slow To Fast	
11		<b>Gobo Rotation (updated 11/19/2019)</b>
	000 – 127	Index
	128 – 189	Clockwise Rotation – Fast to Slow
	190 – 193	Stop
	194 – 255	Counterclockwise Rotation – Slow to Fast
12		<b>Prism 1</b>
	000 – 007	Close
	008 – 255	Open
13		<b>R-Prism 1 (updated 11/19/2019)</b>
	000 – 127	Index
	128 – 190	Clockwise Rotation – Fast to Slow
	191 – 192	Stop
193 – 255	Counter-Clockwise Rotation – Slow to Fast	
14		<b>Prism 2</b>
	000 – 007	Close
	008 – 255	Open

Channel	Value	Function
15		<b>R-Prism 2 (updated 11/19/2019)</b>
	000 – 127	Index
	128 – 190	Clockwise Rotation – Fast to Slow
	191 – 192	Stop
	193 – 255	Counter-Clockwise Rotation – Slow to Fast
16		<b>Strobe</b>
	000 – 003	Light OFF
	004 – 103	Strobe At Linearly Variable Frequency (Low – High)
	104 – 107	Light ON
	108 – 207	Pulsation At Linearly Variable Speed, (Slow – Fast)
	208 – 212	Light ON
	213 – 225	Random Strobe At Low Frequency
	226 – 238	Random Strobe At Medium Frequency
	239 – 251	Random Strobe At High Frequency
17	000 - 255	<b>Dimmer</b> 0% – 100%
18	000 – 255	<b>Focus</b> 0% – 100%
19	000 – 255	<b>Zoom</b> 0% - 100%
20		<b>Frost</b>
	000 – 007	Close
	008 – 255	Open
21		<b>Pan/Tilt Speed (updated 11/19/2019)</b>
	000 – 254	Fast to Slow
	255	Fast
22		<b>Special Function</b>
	000 – 069	No Function
	070 – 079	Blackout While Pan Tilt Move Enable
	080 – 089	Blackout While Pan Tilt Move Disable
	090 – 099	Blackout While Color Move Enable
	100 – 109	Blackout While Color Move Disable
	110 – 119	Blackout While Gobo Move Enable
	120 – 129	Blackout While Gobo Move Disable
	130 – 139	Lamp On
	140 – 149	Reset XY
	150 – 159	Reset Effect
	160 – 199	No Function
	200 – 209	Reset All
	210 – 230	No Function
	231 – 239	Lamp Off
240 – 255	No Function	

**24 Channels:**

Channel	Value	Function
1	000 - 255	<b>Pan</b> 0° - 540°
2	000 - 255	<b>Pan Fine</b>
3	000 - 255	<b>Tilt</b> 0° - 270°
4	000 - 255	<b>Tilt Fine</b>
5	000 - 255	<b>Cyan</b> 0% - 100%
6	000 - 255	<b>Magenta</b> 0% - 100%
7	000 - 255	<b>Yellow</b> 0% - 100%
8		<b>Color</b>
	000 - 005	White
	006 - 011	Red
	012 - 017	Dark Orange
	018 - 023	Dark Green
	024 - 029	Dark Blue
	030 - 035	Pink
	036 - 041	Light Purple
	042 - 047	Light Green
	048 - 053	Light Orange
	054 - 059	Cyan
	060 - 127	White to Cyan
	128 - 189	Clockwise Rotation Fast to Slow
	190 - 193	Stop
	194 - 255	Counter-Clockwise Rotation Slow To Fast

Channel	Value	Function
9		<b>Static Gobo</b>
	000 - 002	White
	003 - 005	Gobo 1
	006 - 008	Gobo 2
	009 - 011	Gobo 3
	012 - 014	Gobo 4
	015 - 017	Gobo 5
	018 - 020	Gobo 6
	021 - 023	Gobo 7
	024 - 026	Gobo 8
	027 - 029	Gobo 9
	030 - 032	Gobo 10
	033 - 035	Gobo 11
	036 - 038	Gobo 12
	039 - 041	Gobo 13
	042 - 044	Gobo 14
	045 - 054	Gobo15
	055 - 058	Gobo1 Shaking Slow To Fast
	059 - 062	Gobo2 Shaking Slow To Fast
	063 - 066	Gobo3 Shaking Slow To Fast
	067 - 070	Gobo4 Shaking Slow To Fast
	071 - 074	Gobo5 Shaking Slow To Fast
	075 - 078	Gobo6 Shaking Slow To Fast
	079 - 082	Gobo7 Shaking Slow To Fast
	083 - 086	Gobo8 Shaking Slow To Fast
	087 - 090	Gobo9 Shaking Slow To Fast
	091 - 094	Gobo10 Shaking Slow To Fast
	095 - 098	Gobo11 Shaking Slow To Fast
	099 - 102	Gobo12 Shaking Slow To Fast
	103 - 106	Gobo13 Shaking Slow To Fast
	107 - 110	Gobo14 Shaking Slow To Fast
	111 - 127	Gobo15 Shaking Slow To Fast
128 - 189	Clockwise Rotation Fast to Slow	
190 - 193	Stop	
194 - 255	Counter-Clockwise Rotation Slow To Fast	

Channel	Value	Function
10		<b>Rotating Gobo</b>
	000 - 006	White
	007 - 013	Gobo1
	014 - 020	Gobo2
	021 - 027	Gobo3
	028 - 034	Gobo4
	035 - 041	Gobo5
	042 - 048	Gobo6
	049 - 055	Gobo7
	056 - 062	Gobo8
	063 - 083	Gobo9
	084 - 087	Gobo1 Shaking Slow To Fast
	088 - 092	Gobo2 Shaking Slow To Fast
	093 - 097	Gobo3 Shaking Slow To Fast
	098 - 102	Gobo4 Shaking Slow To Fast
	103 - 107	Gobo5 Shaking Slow To Fast
	108 - 112	Gobo6 Shaking Slow To Fast
	113 - 117	Gobo7 Shaking Slow To Fast
	118 - 122	Gobo8 Shaking Slow To Fast
	123 - 127	Gobo9 Shaking Slow To Fast
128 - 189	Clockwise Rotation Fast to Slow	
190 - 193	Stop	
194 - 255	Counter-Clockwise Rotation Slow To Fast	
11		<b>Gobo Rotation (updated 11/19/2019)</b>
	000 - 127	Index
	128 - 189	Clockwise Rotation - Fast to Slow
	190 - 193	Stop
	194 - 255	Counter-Clockwise Rotation - Slow to Fast
12		<b>Prism 1</b>
	000 - 007	Close
	008 - 255	Open
13		<b>R-Prism 1 (updated 11/19/2019)</b>
	000 - 127	Index
	128 - 190	Clockwise Rotation - Fast to Slow
	191 - 192	Stop
193 - 255	Counter-Clockwise Rotation - Slow to Fast	
14		<b>Prism 2</b>
	000 - 007	Close
	008 - 255	Open

Channel	Value	Function
15		<b>R-Prism 2 (updated 11/19/2019)</b>
	000 – 127	Index
	128 – 190	Clockwise Rotation – Fast to Slow
	191 – 192	Stop
	193 – 255	Counter-Clockwise Rotation – Slow to Fast
16		<b>Strobe</b>
	000 – 003	Light Off
	004 – 103	Strobe At Linearly Variable Frequency (Low – High)
	104 – 107	Light On
	108 – 207	Pulsation At Linearly Variable Speed (Slow – Fast)
	208 – 212	Light On
	213 – 225	Random Strobe At Low Frequency
	226 – 238	Random Strobe At Medium Frequency
	239 – 251	Random Strobe At High Frequency
	252 - 255	Light On
17	000 – 255	<b>Dimmer</b> 0% – 100%
18	000 – 255	<b>Focus</b> 0% - 100%
19	000 – 255	<b>Focus Fine</b> 0% - 100%
20	000 – 255	<b>Zoom</b> 0% – 100%
21	000 – 255	<b>Focus Fine</b> 0% – 100%
22		<b>Frost</b>
	000 – 007	Close
	008 – 255	Open
23		<b>Pan/Tilt Speed (updated 11/19/2019)</b>
	000 – 254	Fast to Slow
	255	Fast



Channel	Value	Function
24		<b>Special Function</b>
	000 – 069	No Function
	070 – 079	Blackout While Pan Tilt Move Enable
	080 – 089	Blackout While Pan Tilt Move Disable
	090 – 099	Blackout While Color Move Enable
	100 – 109	Blackout While Color Move Disable
	110 – 119	Blackout While Gobo Move Enable
	120 – 129	Blackout While Gobo Move Disable
	130 – 139	Lamp On
	140 – 149	Reset XY
	150 – 159	Reset Effect
	160 – 199	No Function
	200 – 209	Reset All
	210 – 230	No Function
	231 – 239	Lamp Off
240 – 255	No Function	

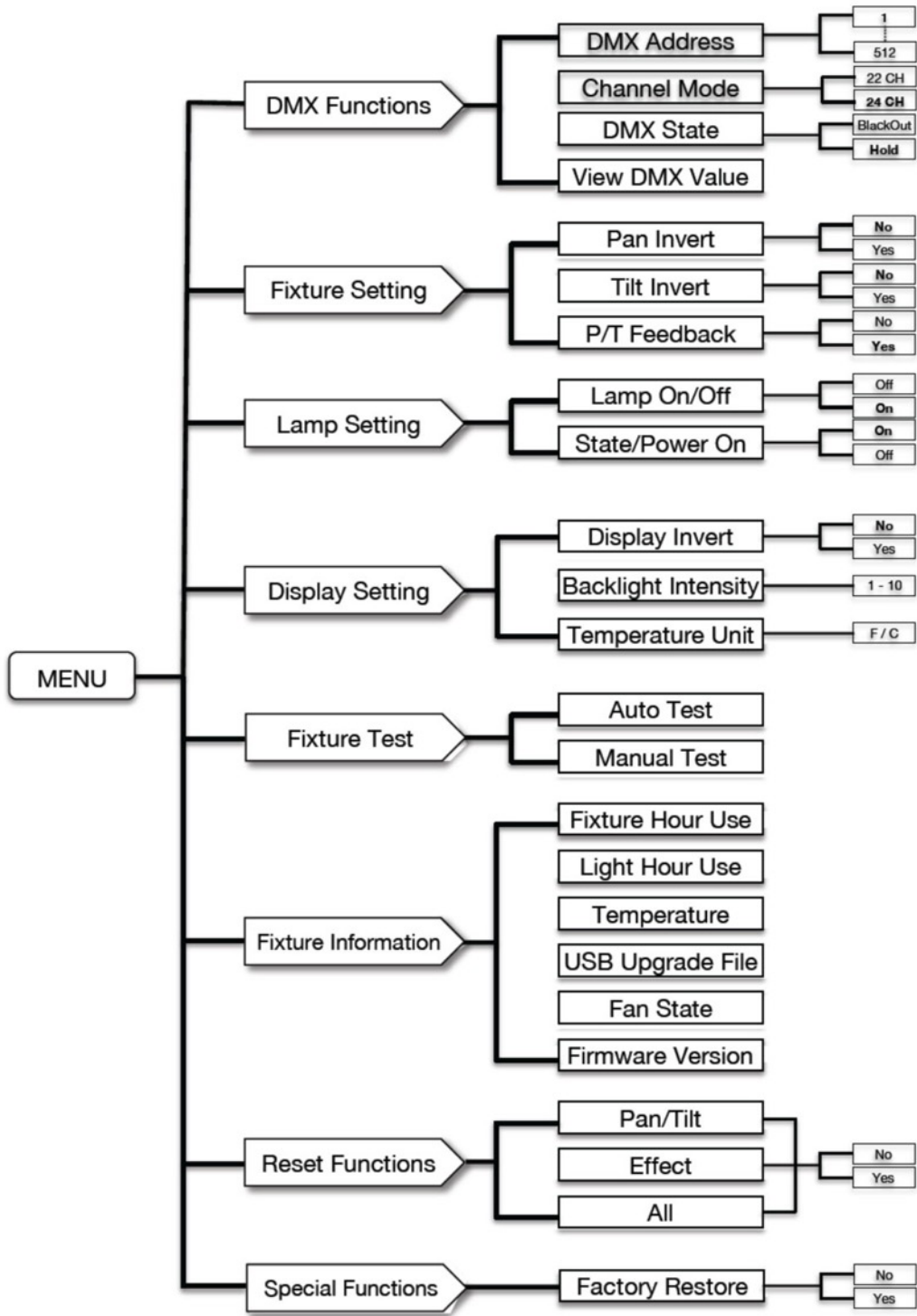

**System Menu:** When making adjustments press **ENTER** to confirm your setup then press and hold the **MENU** button for at least 3 seconds. To exit without making any adjustments press the **MENU** button. The display will lock after 30 seconds; press the **MENU** button for 3 seconds to unlock.

### DMX FUNCTIONS

**DMX Address:** With this function, you can adjust the desired DMX address via the Control Board.

1. Access the main menu, and press the **UP** or **DOWN** buttons so that “DMX Settings” is highlighted, then press **ENTER**.
2. Press the **UP** or **DOWN** buttons until “DMX Address” is displayed, and press **ENTER**. The current DMX address will now be displayed.
3. Use the **UP** or **DOWN** buttons to adjust the DMX address.
4. Press **ENTER** to confirm or press **MENU** button to return to the main menu.

**DMX Channel Mode:** With this function, you can select your desired DMX Channel Mode.

1. Access the main menu, and press the **UP** or **DOWN** buttons so that “DMX Settings” is highlighted, then press **ENTER**.
2. Press the **UP** or **DOWN** buttons until “Channel Mode” is displayed, and press **ENTER**. The number of DMX channels will now be displayed.
3. Press the **MENU** button to return to the main menu.

**DMX State:** This mode can be used as a precaution mode, that in case the DMX signal is lost, interrupted, or power is lost, the operating mode chosen in this setup is the running mode the fixture will go into when the DMX signal is lost. You can also set this as the running mode you would like the unit to return to when power is applied.

1. Access the main menu, and press the **UP** or **DOWN** buttons so that “DMX Settings” is highlighted, then press **ENTER**.
2. Press the **UP** or **DOWN** buttons until “DMX State” is displayed, and press **ENTER**. Use the **UP** and **DOWN** buttons to switch between the two modes (Blackout or Hold). Press the **ENTER** button to make your selection.
  - **HOLD** - If the DMX signal is lost the fixture will stay in the last DMX setting. If power is applied and this mode is set, the unit will automatically go into the last DMX set up.
  - **BLACKOUT** - If the DMX signal is lost or interrupted, the unit will automatically go into stand by mode.
3. Press the **MENU** button to return to the main menu.

**View DMX Value:** This function will allow you to see the DMX value of each DMX channel that is currently being used at the time.

1. Access the main menu, and press the **UP** or **DOWN** buttons so that “DMX Settings” is highlighted, then press **ENTER**.
2. Press the **UP** or **DOWN** buttons until “DMX Value” is displayed, and press **ENTER**.
3. A DMX Channel will be displayed. **Example:** Prism, Color Wheel, Gobo Wheel, etc. Press **ENTER** when you find the DMX channel that you would like to check. When you press **ENTER** the DMX value of that channel will displayed.
4. Press the **MENU** button to exit and return to the main menu.

### FIXTURE SETTING

**Pan Invert:** With this function, you can reverse the Pan movement.

1. Access the main menu, and press the **UP** or **DOWN** buttons so that “Fixture Settings” is highlighted, then press **ENTER**.
2. Press the **UP** or **DOWN** buttons until “Pan Invert” is displayed, and press **ENTER**. The current setting will now be displayed.
3. Use the **UP** or **DOWN** buttons to switch between “YES” and “NO”. Selecting “YES” will activate pan invert, “NO” will deactivate the function.
4. Press **ENTER** to confirm your selection or press the **MENU** button to return to the main menu.

**Tilt Invert:** With this function, you can reverse the Tilt movement.

1. Access the main menu, and press the **UP** or **DOWN** buttons so that “Fixture Settings” is highlighted, then press **ENTER**.
2. Press the **UP** or **DOWN** buttons until “Tilt Invert” is displayed, and press **ENTER**. The current setting will now be displayed.
3. Use the **UP** or **DOWN** buttons to switch between “YES” and “NO”. Selecting “YES” will activate tilt invert, “NO” will deactivate the function.
4. Press **ENTER** to confirm your selection or press the **MENU** button to return to the main menu.

**P/T Feedback:** With this function, you have the pan and tilts position feedback while out of step or not feedback while out of step.

1. Access the main menu, and press the **UP** or **DOWN** buttons so that “Fixture Settings” is highlighted, then press **ENTER**.
2. Press the **UP** or **DOWN** buttons until “P/T Feedback” is displayed, and press **ENTER**. The current setting will now be displayed.
3. Use the **UP** or **DOWN** buttons to switch between “YES” and “NO”. Selecting “YES” will activate feedback, “NO” will deactivate the function.
4. Press **ENTER** to confirm your selection or press the **MENU** button to return to the main menu.

## LAMP SETTINGS

**Lamp On/Off:** With this function, switch the lamp On or Off from the control board.

1. Access the main menu, and press the **UP** or **DOWN** buttons so that “Lamp Settings” is highlighted, then press **ENTER**.
2. Press the **UP** or **DOWN** buttons until “Lamp On/Off” is displayed, and press **ENTER**. The current setting will now be displayed.
3. Use the **UP** or **DOWN** buttons to switch between “On” or “Off”. Selecting “On” will strike the lamp; “Off” will turn off the lamp.
4. Press **ENTER** to confirm your selection or press the **MENU** button to return to the main menu.

**State/Power On:** With this function, you can switch the lamp On or Off while the fixture power is on.

1. Access the main menu, and press the **UP** or **DOWN** buttons so that “Lamp Settings” is highlighted, then press **ENTER**.
2. Press the **UP** or **DOWN** buttons until “State/Power On” is displayed, and press **ENTER**. The current setting will now be displayed.
3. Use the **UP** or **DOWN** buttons to switch between “On” or “Off”. To keep the lamp lit while the fixture power is on select “On”, select “Off” to turn the lamp off while fixture power is on.
4. Press **ENTER** to confirm your selection or press the **MENU** button to return to the main menu.

## DISPLAY SETTING

**Display Invert:** With this function, you can “flip” the display 180 degrees.

1. Access the main menu, and press the **UP** or **DOWN** buttons so that “Display Setting” is highlighted, then press **ENTER**.
2. Press the **UP** or **DOWN** buttons until “Display Invert” is displayed, and press **ENTER**. The current setting will now be displayed.
3. Use the **UP** or **DOWN** buttons to switch between “No” or “Yes”. Selecting “Yes” will “flip” the display, “No” will return the display to normal.
4. Press **ENTER** to confirm your selection or press the **MENU** button to return to the main menu.

**Backlight Intensity:** With this function, you can adjust the intensity of the display backlight.

1. Access the main menu, and press the **UP** or **DOWN** buttons so that “Display Setting” is highlighted, then press **ENTER**.
2. Press the **UP** or **DOWN** buttons until “Backlight Intensity” is displayed, and press **ENTER**. The current setting will now be displayed.
3. Use the **UP** or **DOWN** buttons to adjust the intensity between 1-10. 1 is the lowest intensity, 10 the brightest.
4. Press **ENTER** to confirm your selection or press the **MENU** button to return to the main menu.

**Temperature Unit:** With this function, you can switch the temperature setting between Celsius and Fahrenheit.

1. Access the main menu, and press the **UP** or **DOWN** buttons so that “Display Setting” is highlighted, then press **ENTER**.
2. Press the **UP** or **DOWN** buttons until “Temperature Unit” is displayed, and press **ENTER**. The current setting will now be displayed.
3. Use the **UP** or **DOWN** buttons to switch between °C or °F.
4. Press **ENTER** to confirm your selection or press the **MENU** button to return to the main menu.

### FIXTURE TEST

**Fixture Test:** With this function, you can run an Auto Test or a Manual Test.

1. Access the main menu, and press the **UP** or **DOWN** buttons so that “Fixture Test” is highlighted, then press **ENTER**.
2. Use the **UP** or **DOWN** buttons to switch between “Auto Test” or “Manual Test”.
3. Press **ENTER** to confirm your selection or press the **MENU** button to return to the main menu.

### FIXTURE INFORMATION

**Fixture Hour Use:** With this function, you can check the fixture running time.

1. Access the main menu, and press the **UP** or **DOWN** buttons so that “Fixture Information” is highlighted, then press **ENTER**.
2. Press the **UP** or **DOWN** buttons until “Fixture Hour Use” is displayed, and press **ENTER**. The fixture running time will now be displayed.
3. Press the **MENU** button to return to the main menu.

**Light Hour Use:** With this function, you can check the lamp running time and reset the lamp running time. **NOTE: The lamp running time should be reset every time the lamp is replaced.**

1. Access the main menu, and press the **UP** or **DOWN** buttons so that “Fixture Information” is highlighted, then press **ENTER**.
2. Press the **UP** or **DOWN** buttons until “Light Hour Use” is displayed, and press **ENTER**. The lamp life running time will now be displayed. Press the **UP** or **DOWN** buttons to switch between “Exit” and “Reset Time”.  
**NOTE: If you have just replaced the lamp select “Reset Time” and press ENTER. The lamp time will now be cleared.**
3. To leave this function select “Exit” and press **ENTER**, or press the **MENU** button to return to the main menu.

**Temperature:** With this function, you can check the fixture temperature.

1. Access the main menu, and press the **UP** or **DOWN** buttons so that “Fixture Information” is highlighted, then press **ENTER**.
2. Press the **UP** or **DOWN** buttons until “Temperature” is displayed, and press **ENTER**. The current fixture temperature will now be displayed.
3. Press the **MENU** button to return to the main menu.

**USB Upgrade File:** This submenu is used for any future software updates. Contact ADJ customer service for help when updating software.

**Fan State:** With this function, you can check the running speed of the fans.

1. Access the main menu, and press the **UP** or **DOWN** buttons so that “Fixture Information” is highlighted, then press **ENTER**.
2. Press the **UP** or **DOWN** buttons until “Fan State” is displayed, and press **ENTER**. The current running speed of the fans will now be displayed.
3. Press the **MENU** button to return to the main menu.

**Firmware Version:** With this function, you can check the current firmware version.

1. Access the main menu, and press the **UP** or **DOWN** buttons so that “Fixture Information” is highlighted, then press **ENTER**.
2. Press the **UP** or **DOWN** buttons until “Firmware Version” is displayed, and press **ENTER**. The current firmware version will now be displayed.
3. Press the **MENU** button to return to the main menu.

## RESET FUNCTIONS

**Pan/Tilt:** With this function, you can reset the pan & tilt motors.

1. Access the main menu, and press the **UP** or **DOWN** buttons so that “Reset Function” is highlighted, then press **ENTER**.
2. Press the **UP** or **DOWN** buttons until “Pan & Tilt” is displayed, and press **ENTER**.
3. Use the **UP** or **DOWN** buttons to switch between “No” or “Yes”. To reset the pan & tilt motors, select “Yes” and press **ENTER**.

**Effects** With this function, you can reset the effect motors.

1. Access the main menu, and press the **UP** or **DOWN** buttons so that “Reset Function” is highlighted, then press **ENTER**.
2. Press the **UP** or **DOWN** buttons until “Effects” is displayed, and press **ENTER**.
3. Use the **UP** or **DOWN** buttons to switch between “No” or “Yes”. To reset the effects motors, select “Yes” and press **ENTER**.

**All -** With this function, you can reset all of the motors.

1. Access the main menu, and press the **UP** or **DOWN** buttons so that “Reset Function” is highlighted, then press **ENTER**.
2. Press the **UP** or **DOWN** buttons until “All” is displayed, and press **ENTER**.
3. Use the **UP** or **DOWN** buttons to switch between “No” or “Yes”. To reset all of the motors, select “Yes” and press **ENTER**.

## SPECIAL FUNCTIONS

**Special Functions:** Within this menu, you can reset the fixture to factory settings.

1. Access the main menu, and press the **UP** or **DOWN** buttons so that “Special Functions” is highlighted, then press **ENTER**.
2. “Factory Restore” will now be displayed, and press **ENTER**.
3. To reset the fixture to factory settings, use the **UP** or **DOWN** buttons to “Yes” and press **ENTER**. If you do not wish to reset to factory settings, highlight “No” and press **ENTER**.

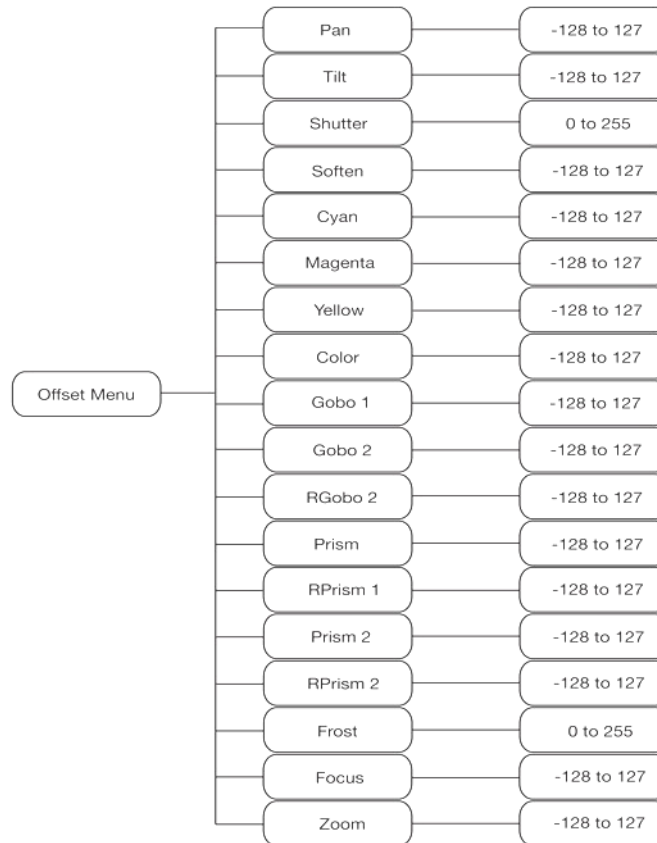

**Offset Menu:** To enter the Offset Menu, press the **ENTER** button for at least 3 seconds. In this submenu you are able to adjust the home position of the pan, tilt, shutter, color wheel, both gobo wheel's, R (rotating) gobo wheel, prism, R (rotating) prism, frost, focus and zoom position.

**Pan:** Adjustment of the pan home position.

1. Press the **ENTER** button for at least 3 seconds, then press the **UP** or **DOWN** buttons so that “Pan” is displayed, press **ENTER**.
2. Use the **UP** and **DOWN** buttons to make your adjustments, and then press **ENTER** to confirm. Press the **MENU** button for one second to exit.



**Tilt:** Adjustment of the tilt home position.

1. Press the **ENTER** button for at least 3 seconds, then press the **UP** or **DOWN** buttons so that “Tilt” is displayed, press **ENTER**.
2. Use the **UP** and **DOWN** buttons to make your adjustments, and then press **ENTER** to confirm. Press the **MENU** button for one second to exit.

**Shutter:** Adjustment of the Shutter.

1. Press the **ENTER** button for at least 3 seconds, then press the **UP** or **DOWN** buttons so that “Shutter” is displayed, press **ENTER**.
2. Use the **UP** and **DOWN** buttons to make your adjustments, and then press **ENTER** to confirm. Press the **MENU** button for one second to exit.

**Soften:** Soften adjustment.

1. Press the **ENTER** button for at least 3 seconds, then press the **UP** or **DOWN** buttons so that “Soften” is displayed, press **ENTER**.
2. Use the **UP** and **DOWN** buttons to make your adjustments, and then press **ENTER** to confirm. Press the **MENU** button for one second to exit.

**Cyan:** Cyan flag home position adjustment.

1. Press the **ENTER** button for at least 3 seconds, then press the **UP** or **DOWN** buttons so that “Cyan” is displayed, press **ENTER**.
2. Use the **UP** and **DOWN** buttons to make your adjustments, and then press **ENTER** to confirm. Press the **MENU** button for one second to exit.

**Magenta:** Magenta flag home position adjustment.

1. Press the **ENTER** button for at least 3 seconds, then press the **UP** or **DOWN** buttons so that “Magenta” is displayed, press **ENTER**.
2. Use the **UP** and **DOWN** buttons to make your adjustments, and then press **ENTER** to confirm. Press the **MENU** button for one second to exit.

**Yellow:** Yellow flag home position adjustment.

1. Press the **ENTER** button for at least 3 seconds, then press the **UP** or **DOWN** buttons so that “Yellow” is displayed, press **ENTER**.
2. Use the **UP** and **DOWN** buttons to make your adjustments, and then press **ENTER** to confirm. Press the **MENU** button for one second to exit.

**Color:** Color wheel home position adjustment.

1. Press the **ENTER** button for at least 3 seconds, then press the **UP** or **DOWN** buttons so that “Color” is displayed, press **ENTER**.
2. Use the **UP** and **DOWN** buttons to make your adjustments, and then press **ENTER** to confirm. Press the **MENU** button for one second to exit.

**Gobo 1:** Gobo wheel 1 home position adjustment.

1. Press the **ENTER** button for at least 3 seconds, then press the **UP** or **DOWN** buttons so that “Gobo 1” is displayed, press **ENTER**.
2. Use the **UP** and **DOWN** buttons to make your adjustments, and then press **ENTER** to confirm. Press the **MENU** button for one second to exit.

**Gobo 2:** Gobo wheel 2 home position adjustment.

1. Press the **ENTER** button for at least 3 seconds, then press the **UP** or **DOWN** buttons so that “Gobo 2” is displayed, press **ENTER**.
2. Use the **UP** and **DOWN** buttons to make your adjustments, and then press **ENTER** to confirm. Press the **MENU** button for one second to exit.

**RGobo 2:** Rotating gobo wheel 2 home position adjustment.

1. Press the **ENTER** button for at least 3 seconds, then press the **UP** or **DOWN** buttons so that “RGobo 2” is displayed, press **ENTER**.
2. Use the **UP** and **DOWN** buttons to make your adjustments, and then press **ENTER** to confirm. Press the **MENU** button for one second to exit.

**Prism:** Prism home position adjustment.

1. Press the **ENTER** button for at least 3 seconds, then press the **UP** or **DOWN** buttons so that “Prism” is displayed, press **ENTER**.
2. Use the **UP** and **DOWN** buttons to make your adjustments, and then press **ENTER** to confirm. Press the **MENU** button for one second to exit.

**RPrism 1:** Rotating prism home position adjustment.

1. Press the **ENTER** button for at least 3 seconds, then press the **UP** or **DOWN** buttons so that “RPrism” is displayed, press **ENTER**.
2. Use the **UP** and **DOWN** buttons to make your adjustments, and then press **ENTER** to confirm. Press the **MENU** button for one second to exit.

**Prism 2:** Prism 2 home position adjustment.

1. Press the **ENTER** button for at least 3 seconds, then press the **UP** or **DOWN** buttons so that “Prism 2” is displayed, press **ENTER**.
2. Use the **UP** and **DOWN** buttons to make your adjustments, and then press **ENTER** to confirm. Press the **MENU** button for one second to exit.

**RPrism 2:** Rotating prism home position adjustment.

1. Press the **ENTER** button for at least 3 seconds, then press the **UP** or **DOWN** buttons so that “RPrism 2 ” is displayed, press **ENTER**.
2. Use the **UP** and **DOWN** buttons to make your adjustments, and then press **ENTER** to confirm. Press the **MENU** button for one second to exit.

**Frost:** Frost home position adjustment.

1. Press the **ENTER** button for at least 3 seconds, then press the **UP** or **DOWN** buttons so that “Frost” is displayed, press **ENTER**.
2. Use the **UP** and **DOWN** buttons to make your adjustments, and then press **ENTER** to confirm. Press the **MENU** button for one second to exit.

**Focus:** Focus home position adjustment.

1. Press the **ENTER** button for at least 3 seconds, then press the **UP** or **DOWN** buttons so that “Focus” is displayed, press **ENTER**.
2. Use the **UP** and **DOWN** buttons to make your adjustments, and then press **ENTER** to confirm. Press the **MENU** button for one second to exit.

**Zoom:** Zoom home position adjustment.

1. Press the **ENTER** button for at least 3 seconds, then press the **UP** or **DOWN** buttons so that “Zoom” is displayed, press **ENTER**.
2. Use the **UP** and **DOWN** buttons to make your adjustments, and then press **ENTER** to confirm. Press the **MENU** button for one second to exit.

If any of these warnings appear and you are not certain on what form of action needs to be taken, please contact ADJ customer support for more information.

**Lamp Startup Fail:** Appears when there is no lamp or some wires are damaged.

**Temperature Sense Error:** Appears when Temperature Check Board is damaged.

**Lamp Too Hot Power Off:** Appears when temperature is detected higher than 110°C. Check if unit is properly ventilated, or fans or Temperature Check Board may be damaged.

**Lamp Too Hot Low Power:** Appears when detected temperature is higher than 105°C. The unit will run on a low power level.

**Lamp On Over 700 Hour:** Appears when the lamp always has been on over 700 hours. Please turn off the lamp.

**Memory Initial Fail:** It appears when the memory IC is damaged.

**CPU-B Error, CPU-C Error, and CPU-D Error:** Message appears when board P.C or some wires are damaged.

**Random Error Messages:** “Pan Reset Error”, “Pan Encode Error”, “Tilt Reset Error”, “Tilt Encode Error”, “Shutter Reset Fail”, “Dimmer Reset Fail”, “Color Reset Fail”, “Cyan Reset Fail”, “Magenta Fail”, “Yellow Reset Fail”, “Gobo1 Reset Fail”, “R-Gobo1 Reset Fail”, “Gobo2 Reset Fail”, “Iris Reset Fail”, “Effect Reset Fail”, “R-Effect Reset Fail”, “Frost Reset Fail”, “Flat Reset Fail”, “Focus Reset Fail” or “Zoom Reset Fail”.

These may appear when turning on or resetting the unit. If some parts such as the PC Board are damaged. Please contact ADJ customer support.

**Caution:** Always replace with the exact same type lamp and fuse, unless otherwise specified by an authorized ADJ service technician. Replacing with anything other than the specified part can damage your unit and will void your manufactures warranty.

**Warning:** If you continue to blow lamps or fuses, STOP using the unit. Contact customer support for further instructions, you may have to return the unit for servicing. Continuing to use the unit may cause serious damage.

**Fuse Replacement:** First unplug the power. The fuse holder is located next to the power connection. Using a Phillips head screwdriver unscrew the fuse holder. Remove the bad fuse and replace with a new one.

**Lamp Replacement:** *Caution! Never attempt to change the lamp while the fixture is plugged in. Always disconnect the main power and allow the unit at least 15 minutes to cool before attempting to replace the lamp. Please see page 7 for important information regarding the discharge lamp. See the next pages for lamp replacement instructions. Be sure to follow the proper handling procedures that deal with discharge lamps.*

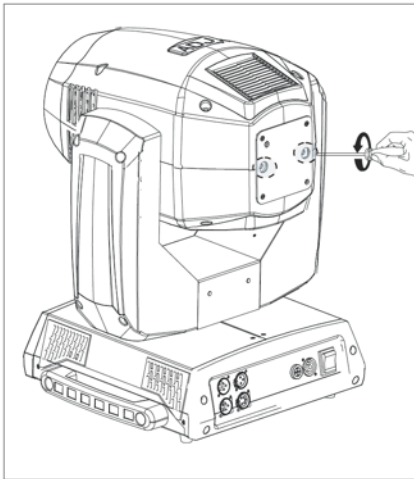

Replacing the lamp is relatively easy. Unplug the unit from its power source. Allow the unit 15 minutes to cool down. Start by unscrewing the two Phillips screws that hold the lamp door in place. **DO NOT UNSCREW THE SCREWS ABOVE AND BELOW THE MAIN SCREWS!**

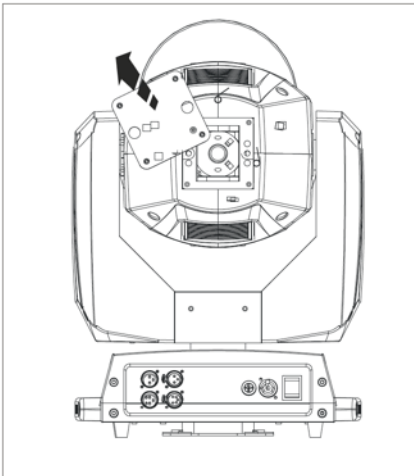

Pull the lamp door out and rotate to the side as the diagram shows. You will now have access to the lamp.

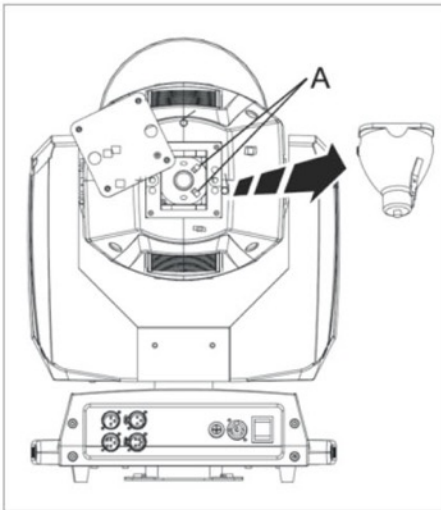

Make sure the moving head is right side up, meaning the lettering is not upside down. Carefully remove the lamp from lamp housing by gently sliding the lamp to the right. It should “pop” out on the left side. You should now be able to remove the lamp from the holders on the right side.

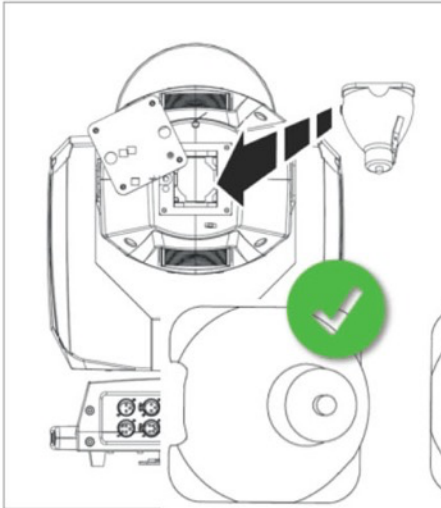

Replace the lamp by placing the new lamp into the right side lamp “sleeves”. Once properly placed in the “sleeves”, gently slide the lamp to the right. Once the lamp is to the right, the lamp can now be placed into the “sleeves” on the left side.

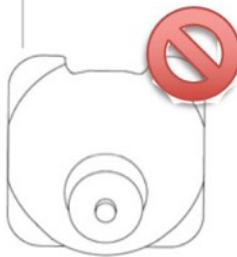

**Fixture Cleaning:** Due to fog residue, smoke, and dust cleaning the internal and external optical lenses and mirror should be carried out periodically to optimize light output. Cleaning frequency depends on the environment in which the fixture operates (i.e. smoke, fog residue, dust, dew). In heavy club use we recommend cleaning on a monthly basis. Periodic cleaning will ensure longevity, and crisp output.

1. Use normal glass cleaner and a soft cloth to wipe down the outside casing.
2. Use a brush to wipe down the cooling vents and fan grill.
3. Clean the external optics and mirror with glass cleaner and a soft cloth every 20 days.
4. Clean the internal optics with glass cleaner and a soft cloth every 30-60 days.
5. Always be sure to dry all parts completely before plugging the unit back in.

The glass gobo's are the only gobo's that are interchangeable in this unit. Remember when changing these gobo's they are glass. Please do this process gently so you do not break the gobo.

**Caution!** *Never open the unit when in use. Always disconnect the main power before attempting to change the gobos.*

1. To change a gobo, rotate the moving head so the instructions on the rear of unit are upside down.
2. Unscrew the 4 screws that secure the shell to the unit. The shell is attached to the unit by a safety wire. Gently lift the shell off of the unit.
3. When you remove the shell, you will be able to access the gobo wheel. Turn the wheel with your hand until you come across the gobo you would like to change.
4. You have to remove the individual gobo frames. Gently push the gobo frame (Not the wheel) away from the gobo wheel; you do not have to the push gobo frame too far. While you are pushing the gobo frame away from the wheel, pull the gobo frame up and out.
5. Once the gobo frame has been removed, gently remove the fixture ring. The fixture ring should easily come out of the frame. After the fixture ring is removed, remove the gobo.
6. Change the gobo and replace the fixture ring. When inserting the gobo frame back into the unit, the bottom of the gobo frame must slide underneath the metal placeholder located at the bottom of the gobo frame slot in the wheel.
7. Reassemble the unit.

**Trouble Shooting:** Listed below are a few common problems that you may encounter, with solutions.

***No light output from the unit;***

1. Make sure the lamp is “On”.
2. Be sure the external fuse has not blown. The fuse is located on the bottom panel of the unit.
3. Remove the lamp holder and be sure the lamp is seated in its socket properly. Occasionally lamps become loose during shipping, be sure the lamp is push in to its socket all the way.
4. Be sure the fuse holder is completely and properly seated.



<b>Model</b>	<b>VIZI CMY 16RX</b>
Voltage:	100~240V, 50/60Hz
Power Consumption:	520 W
Power Draw @ 120V:	5.2 amps
Power Draw @ 220V:	2.4 amps
Lamp:	Philips Platinum 16R MSD
Color Temperature:	8,000K
Life Expectancy:	1,500 Hours
Beam Angle:	10 Degrees (Beam Mode) 5 – 22 Degrees (Spot Mode) 22 – 63 Degrees (Wash Mode)
Zoom Range:	6 – 22 Degrees
Shutter:	Motorized
Zoom:	Motorized
Focus:	Motorized
Prism:	5 Facet Linear 16 Facet Circular w/ Macros, Rotating & Layering
Frost:	Frost Filter + Wash Effect
Strobe/Shutter Rate:	0.3 – 7HZ
Colors:	Full CMY Color Mixing Additional color wheel with 9 colors + white
Gobos:	Wheel 1: 9 static gobos and 6 static apertures Wheel 2: 9 rotating, replaceable gobos
Glass Gobo Size:	15.8 mm (12mm viewable)
Fuse:	10A
Control:	DMX, Stand Alone, RDM (Remote Device Management)
DMX:	3/5pin with 22/24 Channels
IP Rating:	IP20
Warranty:	1 Year (365 Days)
Dimensions (LxWxH):	25" x 16.25" x 13" (639x413x326mm)
Weight:	52lbs / 23.2 kg

**Please Note:** Specifications and improvements in the design of this unit and this manual are subject to change without any prior written notice.

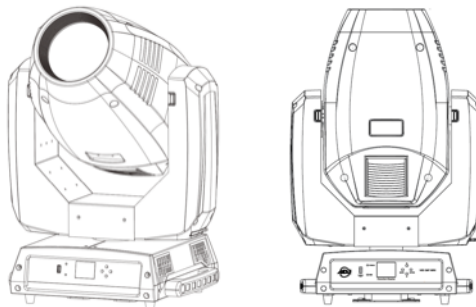



**MANUFACTURER'S LIMITED WARRANTY**

A. ADJ Products, LLC hereby warrants, to the original purchaser, ADJ Products, LLC products to be free of manufacturing defects in material and workmanship for a prescribed period from the date of purchase (see specific warranty period on reverse). This warranty shall be valid only if the product is purchased within the United States of America, including possessions and territories. It is the owner's responsibility to establish the date and place of purchase by acceptable evidence, at the time service is sought.

**B. For warranty service, you must obtain a Return Authorization number (RA#) before sending back the product—please contact ADJ Products, LLC Service Department at 800-322-6337.** Send the product only to the ADJ Products, LLC factory. All shipping charges must be pre-paid. If the requested repairs or service (including parts replacement) are within the terms of this warranty, ADJ Products, LLC will pay return shipping charges only to a designated point within the United States. If the entire instrument is sent, it must be shipped in its original package. No accessories should be shipped with the product. If any accessories are shipped with the product, ADJ Products, LLC shall have no liability whatsoever for loss of or damage to any such accessories, or for the safe return thereof.

C. This warranty is void if the serial number has been altered or removed; if the product is modified in any manner which ADJ Products, LLC concludes, after inspection, affects the reliability of the product, if the product has been repaired or service by anyone other than ADJ Products, LLC factory unless prior written authorization was issued to purchaser by ADJ Products, LLC; if the product is damaged because not properly maintained as set forth in the instruction manual.

D. This is not a service contract, and this warranty does not include maintenance, cleaning or periodic check up. During the period specified above, ADJ Products, LLC will replace defective parts at its expense with new or refurbished parts, and will absorb all expenses for warranty service and repair labor by reason of defects in material or workmanship. The sole responsibility of ADJ Products, LLC under this warranty shall be limited to the repair of the product, or replacement thereof, including parts, at the sole discretion of ADJ Products, LLC. All products covered by this warranty were manufactured after August 15, 2012, and bear identifying marks to that effect.



E. ADJ Products, LLC reserves the right to make changes in design and/or improvements upon its products without any obligation to include these changes in any products theretofore manufactured.

No warranty, whether expressed or implied, is given or made with respect to any accessory supplied with products described above. Except to the extent prohibited by applicable law, all implied warranties made by ADJ Products, LLC in connection with this product, including warranties of merchantability or fitness, are limited in duration to the warranty period set forth above. And no warranties, whether expressed or implied, including warranties of merchantability or fitness, shall apply to this product after said period has expired. The consumer's and/or Dealer's sole remedy shall be such repair or replacement as is expressly provided above; and under no circumstances shall ADJ Products, LLC be liable for any loss or damage, direct or consequential, arising out of the use of, or inability to use, this product.

This warranty is the only written warranty applicable to ADJ Products, LLC Products and supersedes all prior warranties and written descriptions of warranty terms and conditions heretofore published.

**MANUFACTURER'S LIMITED WARRANTY PERIODS:**

- **Non L.E.D. Lighting Products = 1-year (365 days) Limited Warranty** (Such as: Special Effect Lighting, Intelligent Lighting, UV lighting, Strobes, Fog Machines, Bubble Machines, Mirror Balls, Par Cans, Trussing, Lighting Stands etc. excluding LED and lamps)
- **Laser Products = 1 Year (365 Days) Limited Warranty** (excludes laser diodes which have 6 month limited warranty)
- **L.E.D. Products = 2-year (730 days) Limited Warranty** (excluding batteries which have a 180 day limited warranty) Note: 2 Year Warranty only applies to purchases within the United States.
- **StarTec Series = 1 Year Limited Warranty** (excluding batteries which have a 180 day limited warranty).
- **ADJ DMX Controllers = 2 Year (730 Days) Limited Warranty**

ITEM	SKU	
Accu-Cable 3-ft, 3-pin male to female DMX cable	AC3PDMX	
Accu-Cable 10-ft, 3-pin male to female DMX cable	AC3PDMX10	
Accu-Cable 15-ft, 3-pin male to female DMX cable	AC3PDMX15	
Accu-Cable 25-ft, 3-pin male to female DMX cable	AC3PDMX25	
Accu-Cable 50-ft, 3-pin male to female DMX cable	AC3PDMX50	
Accu-Cable 3-ft, 5-pin male to female DMX cable	AC5PDMX	
Accu-Cable 10-ft, 5-pin male to female DMX cable	AC5PDMX10	
Accu-Cable 15-ft, 5-pin male to female DMX cable	AC5PDMX15	
Accu-Cable 25-ft, 5-pin male to female DMX cable	AC5PDMX25	
Accu-Cable 50-ft, 5-pin male to female DMX cable	AC5PDMX50	



DRCVIZI Road Case  
(Sku: DRCVIZI)



DMX Terminator Kit  
(Sku: DMX T-PACK)



10A GMA Single Fuse  
(Sku: Z-FUSE/GMA-10A)

Additional parts and accessories available at [www.adj.com](http://www.adj.com)

